

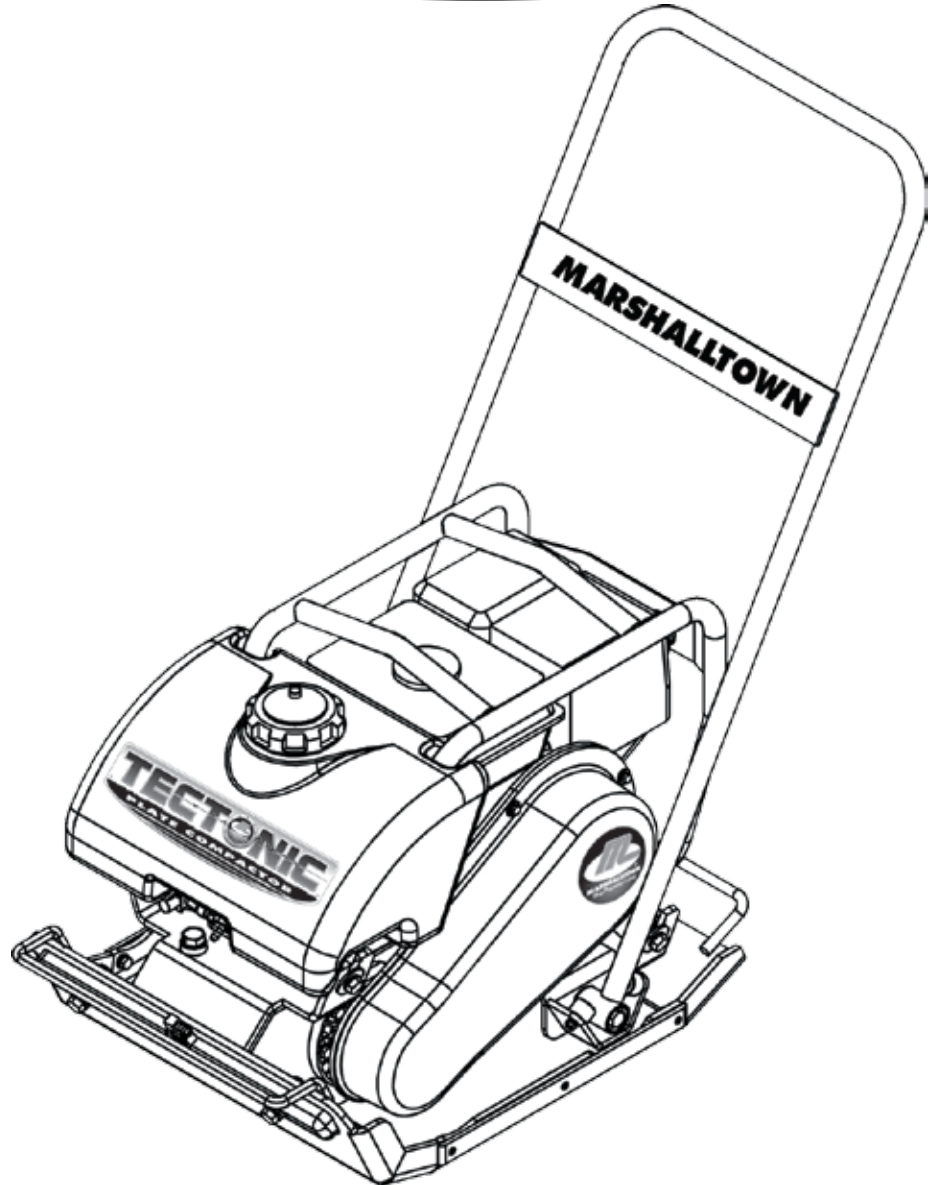

**MARSHALLTOWN**  
The Premier Line



## ***OPERATIONS MANUAL***

***PC3000 - with water tank***  
***PC3000T - w/o water tank***

104 S. 8th Ave.  
Marshalltown, IA  
Phone 800-888-0127 / 641-753-0127  
Fax 800-477-6341 / 641-753-6341  
[www.MARSHALLTOWN.com](http://www.MARSHALLTOWN.com)  
20073

# TABLE OF CONTENTS

FOREWORD .....	3
WARRANTY .....	4
INTRODUCTION .....	5
Introduction & Operating Principle .....	5
Machine Diagram .....	5
TECHNICAL DATA.....	6-7
Serial Number Locator .....	6
Operator Controls.....	7
Machine Dimensions.....	7
HEALTH & SAFETY .....	8-11
OPERATION.....	12-16
Delivery Inspection.....	12
Handle Assembly .....	12
Before Starting .....	12
Water System.....	13
To Start.....	14
To Stop .....	14
Using the Compactor .....	14
Fuel Tank.....	15
Cleaning and Storage .....	15
Lift Points.....	15
Know Your Machine.....	16
Compaction Tips .....	16
MAINTENANCE .....	17-19
Important Maintenance Information .....	17
Engine .....	17
Engine Oil.....	18
Air Filter.....	18
Eccentric Oil.....	17
Hardware.....	18
Belt Tension.....	18
Belt Adjustment.....	18
Offset Eccentric Sheave.....	18
Maintenance Chart.....	19
Troubleshooting.....	20-21
Maintenance Log.....	20

These instructions include:

Safety regulations, operating instructions & maintenance instructions

- These instructions have been prepared for operation on the construction site and for the maintenance engineer.
- These instructions are intended to simplify operation of the machine and to avoid malfunctions through improper operation.
- Observing the maintenance instructions will increase the reliability and service life of the machine when used on the construction site and reduce repair costs and downtimes.
- Always keep these instructions at the place of use of the machine.
- Only operate the machine as instructed and follow these instructions.
- Observe the safety regulations as well as the guidelines of the civil engineering trade association. Observe the safety rules for the operation of compactors and the pertinent regulations for the prevention of accidents.
- Marshalltown Company is not liable for the function of the machine when used in an improper manner and for other than the intended purpose.
- Operating errors, improper maintenance and the use of incorrect operating materials are not covered by the warranty.
- The above information does not extend the warranty and liability conditions of business of Marshalltown Company.

Please enter the following data. This will help expedite any service or warranty work.

1. Machine Type: \_\_\_\_\_

Machine S/N: \_\_\_\_\_

2. Engine Type: \_\_\_\_\_

Engine S/N: \_\_\_\_\_

3. Purchase Date: \_\_\_\_\_

4. Dealer/Distributor Information:

Name: \_\_\_\_\_

Address: \_\_\_\_\_

Phone #: \_\_\_\_\_

Fax # \_\_\_\_\_

Location of warranty information:

# LIMITED WARRANTY

The manufacturer warrants that products manufactured shall be free from defects in material and workmanship that develop under normal use for a period of one year from date of shipment. The warranty is two years for eccentric bearings on the forward plate compactors.

Our warranty excludes normal replaceable wear items, i.e. gaskets, wear plates, seals, O-rings, V-belts, drive chains, clutches, etc. Any equipment, part or product which is furnished by the manufacturer but manufactured by another, bears only the warranty given by such other manufacturer.

The manufacturer's sole responsibility for any breach of the foregoing provision of this contract, with respect to any product or part not conforming to the Warranty or the description herein contained, is at its option (a) to repair, replace or refund such product or parts upon the prepaid return thereof to location designated specifically by the manufacturer. Product returns not shipped prepaid or on an economical transportation basis will be refused (b) as an alternative to the foregoing modes of settlement - the manufacturer's dealer to repair defective units with reimbursement for expenses, except labor, and be reviewed with the manufacturer prior to repair. A Warranty Claims Form must accompany all warranty claims. Warranty is voided by product abuse, alterations, and use of equipment in applications for which it was not intended, use of non-manufacturer parts, or failure to follow documented service instructions.

Except as set forth hereinabove and without limitation of the above, there are no warranties or other affirmations, which extend beyond the description of the products and the fact hereof, or as to operational efficiency, product reliability or maintainability or compatibility with products furnished by others. In no event whether as a result of breach of contract or warranty or alleged negligence, shall the manufacturer be liable for special or consequential damages including but not limited to: Loss of profits or revenues, loss of use of the product or any associated product, cost of capital, cost of substitute products, facilities or services or claims of customers.

No claim will be allowed for products lost or damaged in transit. Such claims should be filed with the carrier within fifteen days.

The foregoing warranty is exclusive of all other warranties whether written or oral, expressed or implied. No warranty of merchantability or fitness for a particular purpose shall apply. The agents, dealer and employees of manufacturer are not authorized to make modification to this warranty, or additional warranties binding on manufacturer. Therefore, additional statements, whether oral or written, do not constitute warranty and should not be relied upon.

Effective January 2009.

**Marshalltown Company**  
**104 S 8th Ave**  
**Marshalltown, IA 50158 U.S.A**

## INTRODUCTION AND OPERATING PRINCIPLE

Congratulations on your purchase of our vibratory plate compactor. This high performance machine has been engineered to provide you with many years of good dependable service. This plate is ergonomically engineered to optimize operator interface with the total machine – it's really "user friendly". Besides good visibility, you'll find that the controls are exactly in the right places for maximum comfort. And it is very convenient to monitor all the consumables – fuel, oil, etc. The engine is equipped with a centrifugal clutch allowing the engine to idle without transmitting rotation to the eccentric.

When the engine runs at operating speed, an eccentric shaft rotates which produces high frequency vibration in the base plate (see Technical Data section for details). With each rotation of the eccentric, the base plate is lifted, moved forward, and slammed down onto the ground. This vibration and force is transmitted to the underlying material, arranging it into a dense mass.

The eccentric shaft is mounted on two heavy open bearings in the eccentric housing which are an integral part of the base plate. The eccentric shaft has a loose fit with the inner race of the bearing which allows turning of the shaft within the bearing. This is normal and will produce some wear on the shaft and bearings. This does not indicate they need to be replaced. The housing is partially filled with oil. The vibration forces oil droplets to jump when the eccentric hits these droplets, it produces an oil mist which is forced into the bearings. This continually lubricates the bearings and flushes away heat.

The eccentric delivers a centrifugal force sufficient to compact all types of soil. Superior vibration isolation to the operator is achieved by mounting heavy-duty shock mounts between the eccentric and support frames. Four rubber vibration isolators are mounted between the base plate and the engine deck to isolate the vibration from the engine, giving it long life.

The following instructions were compiled to provide you information on how to obtain long and trouble-free use. Periodic maintenance is essential. Read this manual in its entirety and follow the instructions carefully. Failure to do so may cause injury to you or a bystander.

## MACHINE DIAGRAM

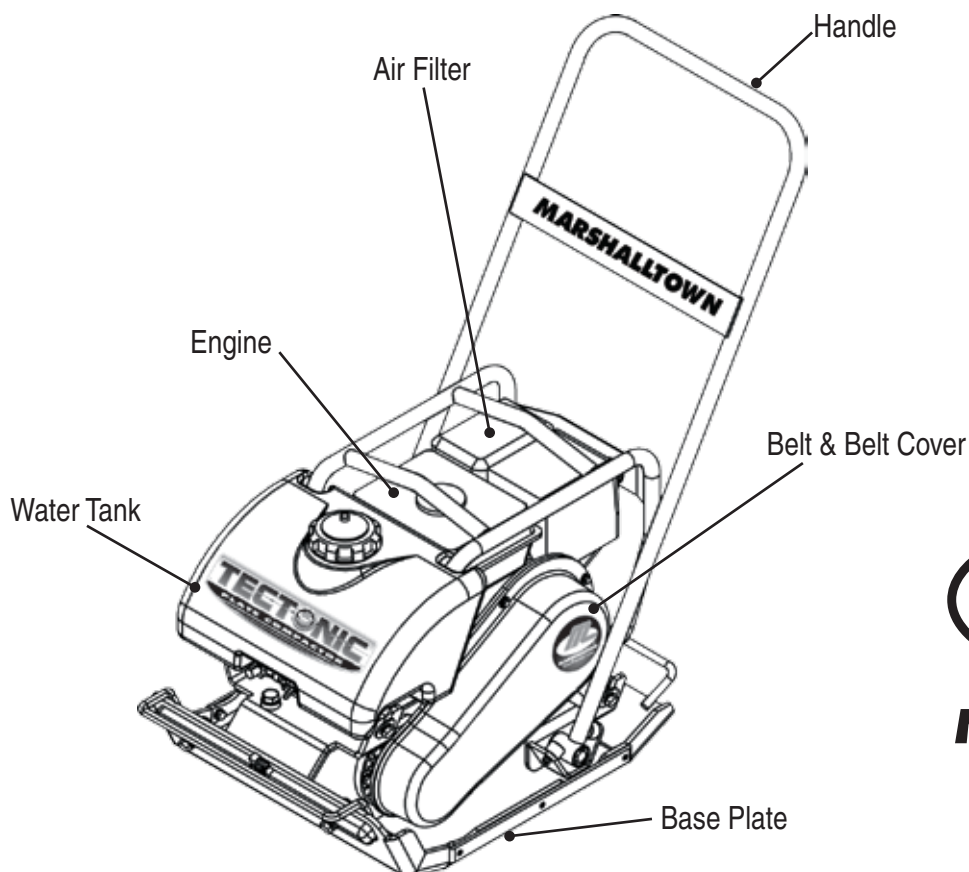

# TECHNICAL DATA

Model Number	PC3000	PC3000T
Weight	205 (93kg)	210lbs (95kg)
Plate Size	20 X 24" (51 X 61cm)	20 X 24" (51 X 61cm)
Engine	Honda 5.5 hp (4,1kW)	Honda 5.5 hp (4,1kW)
Engine Speed (Operating)	3400 RPM	3400 RPM
Idle Speed	1700 RPM	1700 RPM
Fuel Capacity	1 gallon (3.8 L)	1 gallon (3.8 L)
Recommended Fuel	Unleaded gasoline 87 octane or higher*	
Eccentric Oil Type**	SAE 30	SAE 30
Spark Plug	NGK BPR 6ES-11	NGK BPR 6ES-11
Spark Plug Gap	.039" (1mm)	.039" (1mm)
Sound Level at Operator Position	95 dba	95 dba
Water System	N/A	Yes
Water Tank Capacity	N/A	13 qt. (12,3 L)
Eccentric Force	3000 lbs (9.8 kN)	3000 lbs (9.8 kN)
Productivity per hour	10,000 sq. ft. (929 sq. M)	10,000 sq. ft. (929 sq. M)
Max Lift	12" (30.5cm)	12" (30.5cm)
Max Travel Speed per min.	100 ft. (30.5 M)	100 ft. (30.5 M)
Vibration Frequency	6000 vpm (100 Hz)	6000 vpm (100 Hz)
Features	Roll cage	Roll cage, Removable water tank
Options	Paving Mat, E-Z Transport Wheels	Paving Mat E-Z, Transport Wheels
Applications	Granular soil, backfill	Asphalt

\* Gasohol blends not recommended

\*\*For engine oil type consult engine manual

## SERIAL NUMBER LOCATOR

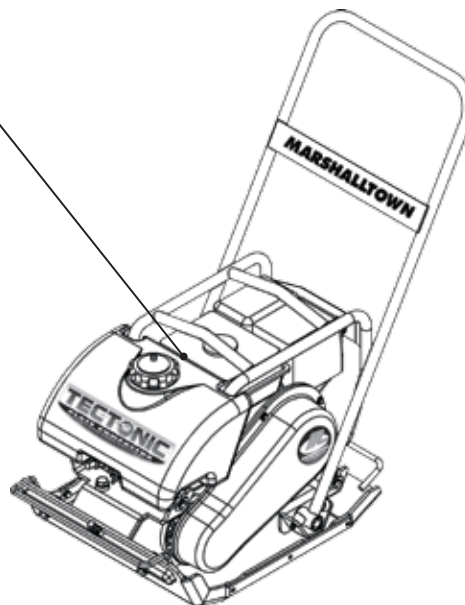

Since the permissible noise level rating of 89 dB(A) can be exceeded with this machine, the operator must wear suitable hearing protection!

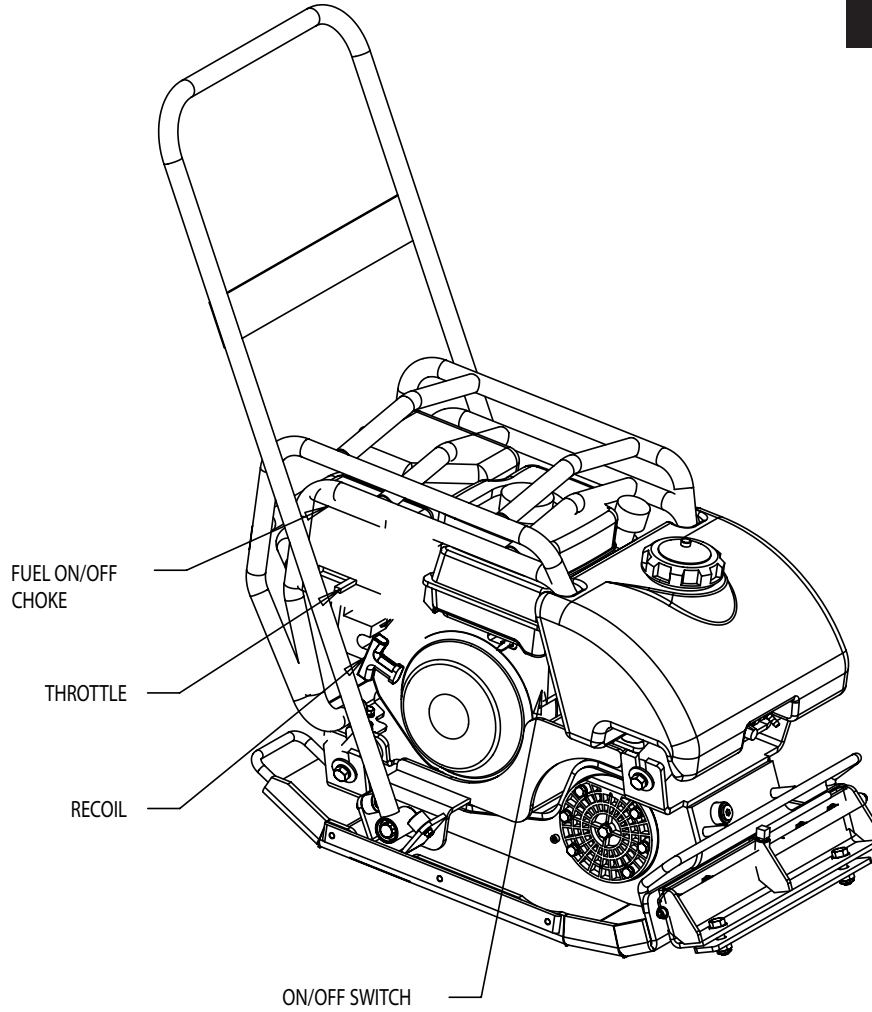

MACHINE DIMENSIONS

PC3000/PC3000T

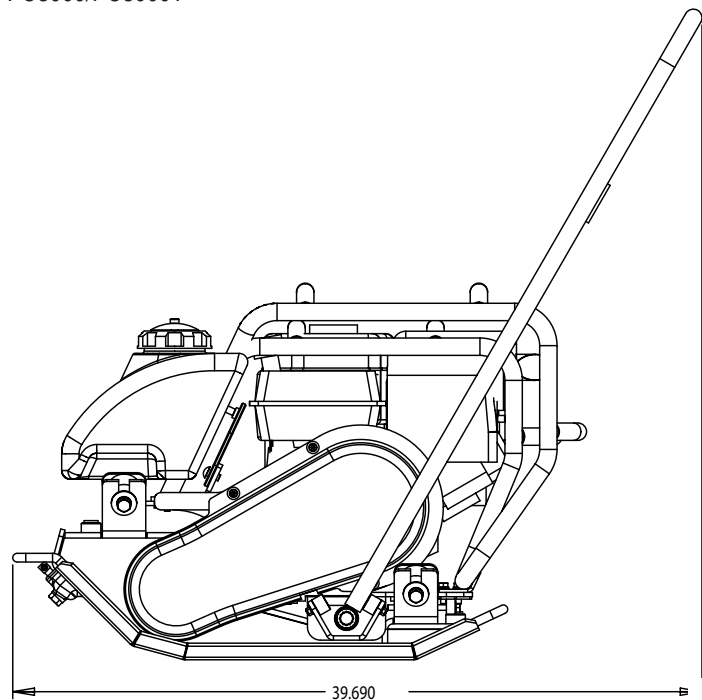
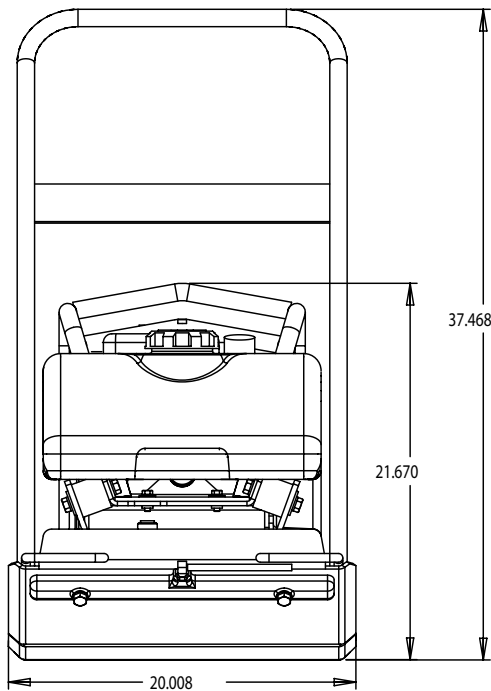

# HEALTH & SAFETY

Before using this equipment, study this entire manual to become familiar with its operation. Do not allow untrained or unauthorized personnel, especially children, to operate this equipment. Use only factory authorized parts for service.

When warning decals are destroyed or missing, contact the manufacturer immediately at 1-800-888-0127 for replacement. For the safety of your self and others, it is imperative that the following rules are observed. Failure to do so may result in serious injury or death.

## DECAL IDENTIFICATION

Part# M55722

<b>NOTICE</b>
If safety or hazard decals or operator's manual are missing from this equipment, contact the manufacturer immediately
<b>AVISO</b>
Si las etiquetas de seguridad o peligro o el manual del operador faltan en este equipo, contactar inmediatamente al fabricante
<small>55722</small>

Part# M55546

<b>IDLE ENGINE 5 MINUTES BEFORE STOPPING TO IMPROVE SERVICE LIFE</b>
DEJE FUNCIONAR EL MOTOR EN VACIO DURANTE 5 MINUTOS ANTES DE DETENERLO PARA EXTENDER SU VIDA DE SERVICIO.
<small>55546</small>

Part# M55550

<b>WARNING</b>
<b>Moving parts can crush and cut.</b> Do not operate with guard removed. Shut off engine to clean or service.
<b>ADVERTENCIA</b>
<b>Las partes móviles pueden ocasionar cortes y aplastamientos.</b> No operar la máquina cuando no esté colocado el protector. Desconectar la máquina para limpiarla o realizar el servicio técnico.
<small>55550</small>

Part# M55548

<b>ECCENTRIC OIL LEVEL</b>
MAINTAIN OIL (SAE30) LEVEL FLUSH WITH SIDE BOLT HOLE. DO NOT OVERFILL.
<b>NIVEL DE ACEITE DE LA EXCENTRICA</b>
MANTENER NIVEL DE ACEITE (SAE30) AL NIVEL DEL AGUJERO DE PERNO LATERAL. NO LLENAR DE MÁS.
<small>55548</small>

Part# M55551

<b>NOTICE</b>
<b>LIFT POINT</b>
<small>55551</small>
<b>AVISO</b>
Punto de izamiento

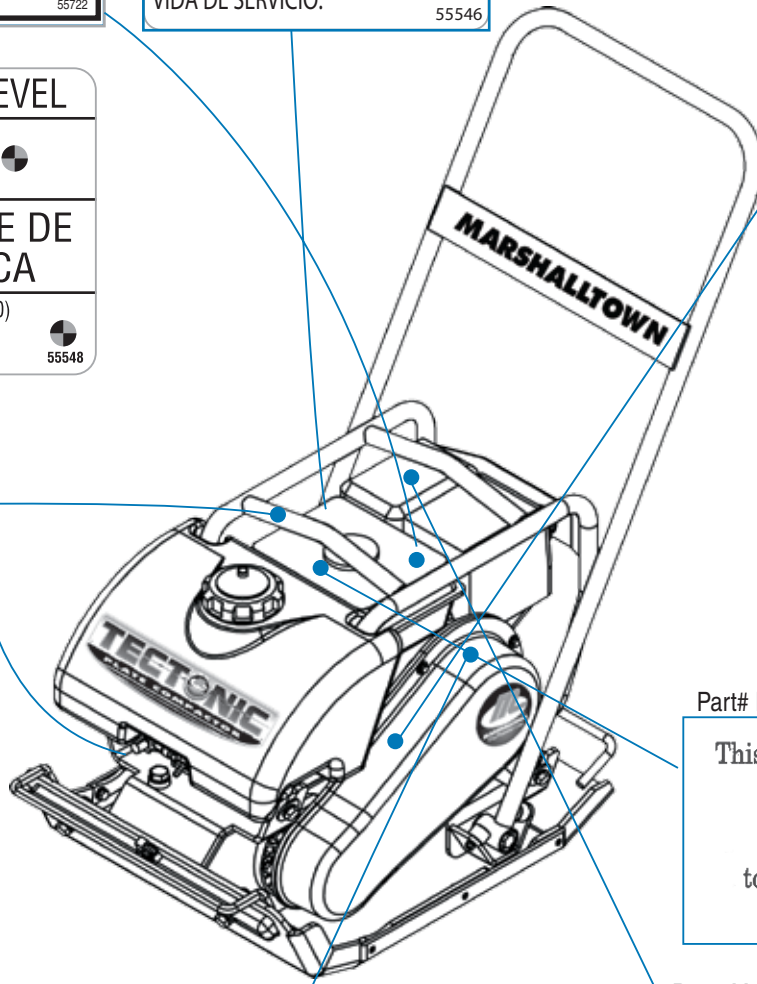

Part# M55214

This engine has been tested with fuel treated with <b>STA-BIL®</b> to prevent gum and varnish residue in tank.
--

Part# M55549

<b>WARNING</b>	<b>ADVERTENCIA</b>
<p>Read and understand operator's manual before using this machine. Follow safety and alert symbols and warnings. Open flame, fire and smoking prohibited. Do not operate in unventilated area. Stop engine before refueling. Use unleaded gasoline, octane rating of 86 or higher. Check the engine oil level before starting. Hearing protection required.</p>	<p>Lea y entienda el manual del operador antes de usar esta máquina. Siga los símbolos y advertencias de seguridad y alerta. Está prohibido prender fuego, exponer a las llamas y fumar. No haga funcionar en ambientes carentes de ventilación. Detenga el motor antes de suministrar combustible. Utilice gasolina sin plomo de 86 octanos o superior. Compruebe el nivel de aceite del motor antes de empezar. Se requiere protección para los oídos.</p>
<small>55549</small>	

Part# M55547

<b>SET ENGINE SPEED TO AJUSTE LA VELOCIDAD DEL MOTOR A 3400+/-50 RPM</b>
<small>55547</small>



## FOLLOW SAFETY INSTRUCTIONS

- Carefully read all safety messages and decals in this manual and on your machine safety signs. Keep decals in good condition. Replace missing or damaged decals. Be sure new equipment components and repair parts include the current safety signs. Replacement safety signs and decals are available through your dealer.
- Learn how to operate the machine and how to use controls properly. Do not let anyone operate without instruction.
- Keep your machine in proper working condition. Unauthorized modifications to the machine may impair the function and/or safety and affect machine life.
- If you do not understand any part of this manual and need assistance, contact your dealer.

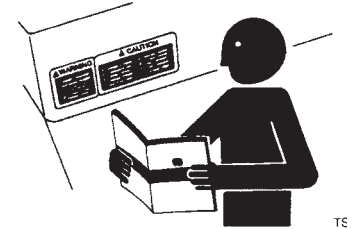

## UNDERSTAND SIGNAL WORDS

- A signal word – DANGER, WARNING, or CAUTION – is used with the safety-alert symbol. DANGER identifies the most serious hazards.
- DANGER or WARNING safety signs are located near specific hazards. General precautions are listed on CAUTION safety signs. IMPORTANT also calls attention to safety messages in this manual.
- This notation appears before warnings in the text. It means that the step that follows must be carried out to avoid the possibility of personal injury or death. These warnings are intended to help the technician avoid any potential hazards encountered in the normal service procedures. We strongly recommend that the reader takes advantage of the information provided to prevent personal injury or injury to others.



**⚠ WARNING**

## PREPARE FOR EMERGENCIES

- Be prepared if a fire starts.
- Keep a first aid kit and fire extinguisher handy.
- Keep emergency numbers for doctors, ambulance service, hospital, and fire department near your telephone



## WEAR PROTECTIVE CLOTHING

- Wear close fitting clothing and safety equipment appropriate to the job.
- Prolonged exposure to loud noise can cause impairment or loss of hearing.
- Wear a suitable hearing protective device such as earmuffs or earplugs to protect against objectionable or uncomfortable loud noises.
- Operating equipment safely requires the full attention of the operator. Do not wear radio or music headphones while operating machine.

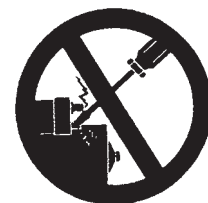

# HEALTH & SAFETY

## PRACTICE SAFE OPERATION

---

- Ear protection required when operating this machine.
- Qualified personnel only. No untrained operators. Serious injury may occur.
- Users must be trained to operate this machine. Read the Operator's Manual and Engine Owner's Manual. Learn to operate this machine safely.
- Do not operate across the sides of hills, machine may tip over.
- Do not operate at the edge of mats or roads, machine may tip over.
- Do not park the machine on hills.
- Keep feet clear of the machine's base plate at all times.
- Be sure no one is in a position to be hit by operator's hand or arm during starting.
- Do not leave the machine running unattended.
- Keep work area free of bystanders.
- Do not operate this machine on any surface where it can get out of control.
- Never operate any gas powered equipment in a poorly ventilated or enclosed area
- Avoid prolonged breathing of exhaust gases.
- Keep hands, clothing and jewelry away from all moving parts.
- Make sure all safety guards are secure and in proper position.

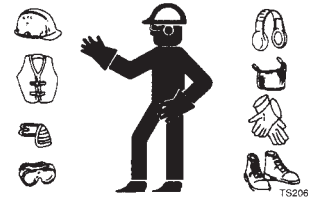

## HOT SURFACES

---

- Muffler, engine, and engine shroud may be hot.
- Allow all components in the engine compartment to cool before performing any service work.



## DISPOSE OF WASTE PROPERLY

---

- Improperly disposing of waste can threaten the environment and ecology. Potentially harmful waste used with equipment include such items as oil, fuel, coolant, brake fluid, filters, and batteries.
- Use leak proof containers when draining fluids. Do not use food or beverage containers that may mislead someone into drinking from them.
- Do not pour waste onto the ground, down a drain, or into any water source.
- Air conditioning refrigerants escaping into the air can damage the Earth's atmosphere. Government regulations may require a certified air conditioning service center to recover and recycle used air conditioning refrigerants.
- Inquire on the proper way to recycle or dispose of waste from your local environmental or recycling center.



## PRACTICE SAFE MAINTENANCE

- Observe the maintenance, inspection and adjustments and intervals specified in the operating instructions, as well as the information for part replacement.
- Maintenance work must be undertaken only by qualified and authorized persons.
- Maintenance and repairs must only be undertaken with the drive stationary.
- Only carry out maintenance and repairs when the machine is parked on a firm and even surface and is secured to prevent it from moving.
- Spare parts must comply with the technical requirements of the manufacturer. Therefore only use original spare parts.
- After completing all work (with the system still pressureless), inspect all connections and bolted connections for leaks.
- Inspect all hoses and bolted connections for leaks at regular intervals (depending on time used), even when no safety-related faults are visible.
- Inspect the electrical equipment of the machine at regular intervals. Faults such as loose connections, worn or scorched cables must be remedied immediately.

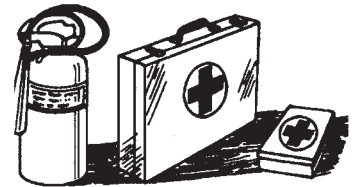

## USE COMMON SENSE WHEN HANDLING FUELS

- Transport and handle fuel only when contained in approved safety containers.
- Do not smoke when refueling the engine or during any other fuel handling operation.
- If fuel is spilled during refueling, wipe it off from the engine immediately and discard the rag in a safe place.
- Do not operate the equipment if fuel or oil leaks exist-repair immediately.
- Never operate this equipment in an explosive atmosphere.
- Starting fluid (ether) is highly flammable, do not use or an explosion or fire may result.



## **SAFETY USE**

These machines are designed to carry out the function of compacting material of the cohesive, bituminous and granular varieties.

If used correctly they will provide an effective and safe means of compaction and meet the appropriate performance standards.

It is essential that the driver/operator of the machine is adequately trained in its safe operation, be authorized to drive it, and have sufficient knowledge of the machine to ensure that it is in full working order before being put to use.

# OPERATION

## DELIVERY INSPECTION

Upon receipt of your compactor, CAREFULLY CHECK FOR ANY FREIGHT DAMAGE. Any damage should be immediately reported to the carrier and a claim registered.

Tectonic™ Vibratory Plates are manufactured to the strictest specifications and inspection procedures. If any material or manufacturing defects are found, please contact Marshalltown Customer Service at 800-888-0127.

The following instructions were compiled to provide you information on how to obtain long and trouble free use of the machine. Periodic maintenance of the machine is essential. Read the manual in its entirety and follow the instructions carefully. Refer to the Technical Data Section to familiarize yourself with machine controls and components. Failure to do so may injure yourself or a bystander.

## HANDLE ASSEMBLY

Compactors are shipped assembled and ready for operation with the exception of attaching the handle assembly. To attach the handle to the compactor, straddle the engine with the handle and secure to the engine deck. Refer to the appropriate main handle assembly drawing in the Exploded Diagrams and Parts section of your Operator/Service Manual. Hardware is packed with the Main Handle Assembly.

### Handle features include:

- One piece tubular handle
- Positive front and back handle stops
- Bar for added vibration absorption



For illustrations, see the appropriate model's assembly drawing.

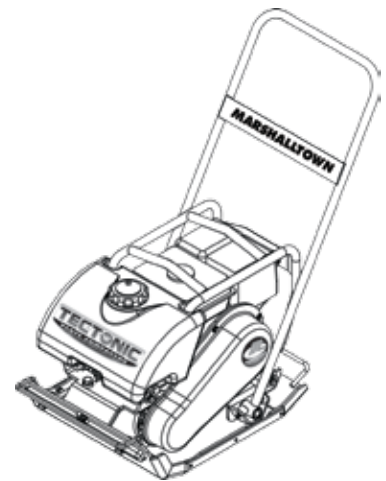

### **WARNING**

**CAUTION:** Disconnect spark plug wires to prevent accidental starting before doing any work.

## BEFORE STARTING

### **WARNING**

Check oil level in engine. Engine warranty is void if run without oil. If oil is required, use SAE 30 if air temperature is over 40 deg. F (4 deg. C) and SAE 5W-40 if below 40 deg. F (4 deg. C).

Fill fuel tank with clean unleaded gasoline from a safety can. Never fill tank with engine running. Do not mix oil with gasoline.

Check all hardware for tightness. Tighten if found loose. Follow torque chart.

## WATER SYSTEM

On model PC3000T a water system is provided for wetting the bottom surface of the compactor to prevent asphalt from sticking when compacting asphalt. After the bottom plate has warmed up from the asphalt and/or from the oil inside the eccentric housing (these plates have self-heating bases), water is less important.

There is a valve with a strainer located at the bottom of the water tank. The rate of flow can be controlled by it. The water is distributed by the sprinkler tube at the front edge of the compactor. If the holes in the sprinkler tube ever get plugged, they can be easily cleaned by blowing air through the tube or removing the sprinkler tube and cleaning out the holes with a thin object such as a paper clip.

The water tank is removable for easy fill-ups. Detach the quick coupler at the valve and rubber latch at back of tank. Tank can come off of rollcage to be filled. Return and reattach water tube in reverse of disassembly.



### **Water System features include:**

- Patented-water system
- SnapTek™ quick-coupler easily detaches and reattaches to tank
- Both systems easy to change out

# OPERATION

## TO START

---

### **WARNING**

**Never run machine with optional wheels attached.**

Apply choke, set throttle, then pull starter once or twice. Open choke slightly to prevent flooding and repeat pulls as necessary. When engine starts, make sure choke is open or in "run" position and set throttle on idle to let engine idle one or two minutes to warm. Push throttle to set unit in motion.

Engine governor will control engine for optimum speed. Be sure control is used either all the way on or all the way off, as intermediate position may interfere with the governor and burn out the clutch.

### **WARNING**

**Never operate compactor on concrete or non-yielding surfaces.**

## TO STOP

---

Move throttle control to idle position. Actuate stop feature located on engine.

## USING THE COMPACTOR

---

With the engine running at full throttle, the unit will move forward in short, rapid jumps. Grasp the handle lightly and let the compactor do the work. Use the handle to guide the direction of the travel around obstructions, holes, etc. Reversible handle may be used to guide the machine in and around corners or up grades. Forward traveling speed of the machine is dependent upon the model used, depth and type of material to be compacted.

Engine Oil--SAE 30 API SH or SJ (oil with "starburst" certification mark) is recommended for general, all temperature use. Check daily for proper oil level. **DO NOT OVERFILL.** See Engine Owner's Manual for specifications.

Gasoline Fuel--Always use fresh, unleaded gasoline (87 octane min.). Fresh gasoline is blended for the season and reduces gum deposits that could clog the fuel system. Do not use gasoline left over from the previous season.

Refer to the Engine Manual for break-in.

**DO NOT MIX OIL WITH FUEL.** The engine has a separate oil reservoir in the crankcase. Unleaded gasoline is recommended for use in the engine since it leaves less combustion chamber deposits.

### **WARNING**

Fuel is both toxic and flammable

Do not smoke while working with fuel

Do not use near open flame

Always stop engine before refueling

Clean up spilled fuel before starting

Avoid fires by keeping engine clean of accumulated grease and debris

Start, store and refuel on level ground to prevent personal injury

Do not run unit in an enclosed, non-ventilated area

Avoid prolonged breathing of vapors and skin contact— serious illness or loss of life could result

## FUEL TANK

-Gasoline ONLY (see Engine Specifications Section for requirements).

Fill fuel tank at the end of each day's operation to prevent condensation in the tank.

Drain and flush fuel tank every 1,000 hours or 12 months.

Avoid storing fuel over long periods of time. If fuel is stored for more than a month prior to use or there is a slow turnover in fuel tank or supply tank, add a fuel conditioner to stabilize the fuel and prevent water condensation. Fuel conditioner also reduces fuel gelling and controls wax separation during cold weather.

Proper fuel storage is critically important. Use clean storage and transfer tanks. Periodically drain water and sediment from the bottom of the tank. Store fuel in a convenient place away from buildings.

## CLEANING AND STORAGE

If equipment is taken out of operation for the Winter season or a prolonged period, follow below procedures to prevent machine or engine damage.

1. Completely clean the outside of the engine.
2. Operate the engine until it is warm. Stop the engine and drain the engine oil from the engine.
3. Drain the fuel system completely.
4. At the end of the storage period, engine oil must be drained and the engine must be filled to the correct level with normal engine oil .

## LIFT POINTS

There are two methods for lifting machine. A lifeye built into rollcage can be used for lifting with straps or crane. Handles located at the front and rear of machine can be used for two people to lift machine up onto elevated surfaces.

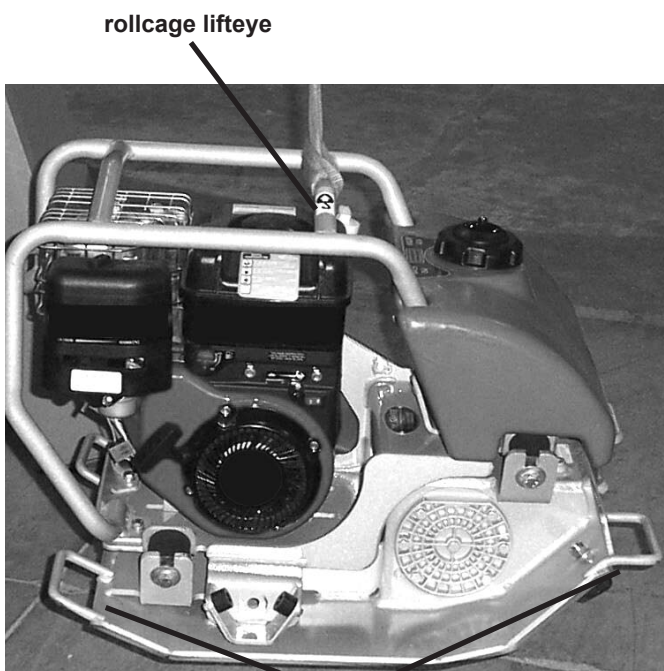

front and rear lift handles

lift handles

# OPERATION

## KNOW YOUR MACHINE

---

Read and understand the owner's manual before starting the unit. Make sure you understand the purpose of every control. When operating the unit, remember the capacity it can carry and adjust speed and load for changing conditions.

Pre-Operation Checklist – Upon receipt of your plate CAREFULLY CHECK FOR ANY FREIGHT DAMAGE. Any damage should be immediately reported to the carrier and a claim registered.

The Tectonic™ Plate is manufactured to the strictest specifications and inspection procedures. After inspecting the quality of the workmanship of your machine, please complete and return the warranty card. We value our customer's input and welcome any and all comments on how the product may serve you better.

The following instructions were compiled to provide you information on how to obtain long and trouble-free use of the unit. Read and understand the owner's manual before starting the unit. Make sure you understand the purpose of every control. When operating the unit, know the capacity it can carry and adjust the speed and load for changing conditions.

## COMPACTION TIPS

---

Due to the high frequency of impacts to the ground, vibratory type compactors are most effective on granular soils such as sand and gravel. To obtain maximum density in the soil to be compacted, an optimum moisture content needs to be present. When the soil is too dry, moisture should be added, when the soil is too wet, let it dry. Soil testing laboratories in your area can tell you what moisture content you have in your soil and if you should add water or let the soil dry. Additionally, they can measure the soil density you are achieving in your compacting.





## IMPORTANT!

The person attempting any of the following maintenance tasks must be authorized to do so and have read and understood all sections within this manual.

### TECTONIC™ MAINTENANCE CHART

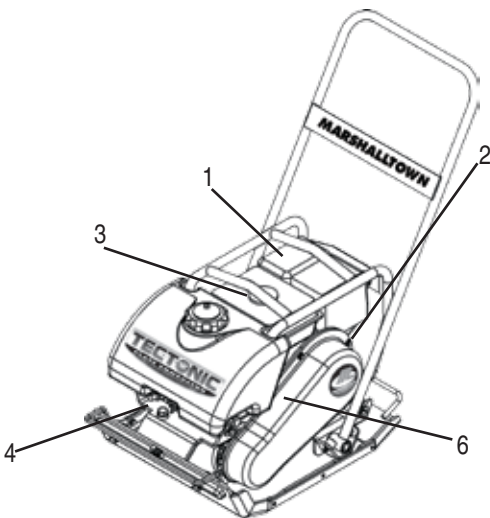

Engine Maintenance Items	Instruction/Schedule
Engine	Read Tectonic™ owner's manual
Air Filter	Check daily, change per engine manual
Engine Oil	Check daily, change per engine manual
Fuel Level	Check daily
Eccentric Oil	Check monthly, replace every 300hrs
Hardware	Check daily for tightness
Belt Tension	Check weekly
General Engine Maintenance	Service annually

### ENGINE

All engines operate at 3400 RPM. Thoroughly service engine at least annually. Follow manufacturer's recommendations including: clean carbon from cylinder head, check intake and exhaust valves, clean and adjust carburetor, check ignition cable and daily check for damaged parts and replace. Check for loose fasteners - tighten as per torque chart.

### ENGINE OIL

Check engine oil level daily. Consult engine manual included with this unit for specific maintenance instructions.

### AIR FILTER

Remove foam pre-cleaner from air filter daily. Wash the foam in liquid detergent and water. Squeeze dry between towels. Oil with one ounce of engine oil and squeeze to distribute oil evenly. Keeping the filter clean prolongs the engine life and decreases fuel consumption.

# MAINTENANCE

## ECCENTRIC OIL

Check eccentric oil monthly. Change oil every 300 hours. Check oil by removing oil plug on side of eccentric housing. Oil should be leveled with bolt hole, see figure 1. If oil is required, use SAE 30 oil. DO NOT OVERFILL.

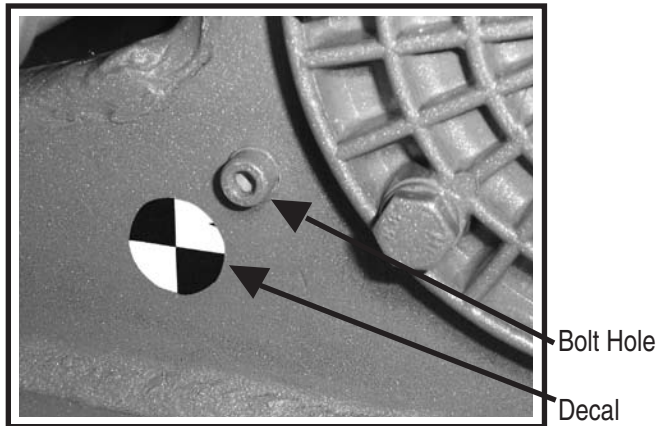

Figure 1



Decal M55548

## HARDWARE

Check daily for tightness. If required, tighten using torque charts in Parts Section.

## BELT TENSION

Check belt tension weekly.

## BELT ADJUSTMENT

Belt is adjusted by loosening four engine bolts and adjusting the engine puller bolt on rear of the engine deck, until desired tension is obtained - then retighten engine bolts. Adjustment should be made when eccentric is down. Using a straight edge maintains sheave alignment while tightening engine mounting bolts. Proper tension is obtained when a two lb. force is applied midway between the two sheaves and a 1/4" to 1/2" (6.4 mm to 12.7 mm) deflection of the belt is obtained. For best performance and longest belt life, use only MARSHALLTOWN specified Kevlar belt.

Adjust belt tension by adjusting engine with puller bolt.



# TROUBLESHOOTING

<b>Engine will not start/or runs irregularly</b>	
Out of gasoline	Fill gas tank.
No spark.	Check for broken wires.
Spark plug fouled.	Replace and set gap to .030 on Honda engines.
Air cleaner clogged.	Clean air filter. Follow procedure outlined in "Maintenance" section of this manual.
Carburetor improperly adjusted.	Close needle valve. Open 1-1/2 turns. With engine running under full load and compactor on an old tire, close the valve until the engine starts to loose speed. Then open until smooth operation is obtained. To adjust idle speed, push throttle against idle stop and adjust screw until an idle of 1700 rpm is obtained. If clutch engages, lower idle speed. <b>CLUTCH MUST NOT ENGAGE.</b>
<b>Plate Does Not Vibrate at Full Speed</b>	
Too much oil in eccentric housing.	Check oil level as specified in "Maintenance" section of this manual.
Loose belt.	Adjust belt tension as in "Maintenance" section of this manual.
<b>Engine is not at 3400 rpm</b>	
Dirt in carburetor.	Clean carburetor and adjust (see "Carburetor out of Adjustment").
Governor out of adjustment	Adjust governor.
<b>Clutch is Hot</b>	
Foreign object lodged against eccentric sheave.	Clean obstruction. CAUTION: Make sure unit is shut off and spark plug wire disconnected.
Too much oil in eccentric housing.	Check oil level as specified in "Maintenance" section of this manual.
Clutch slipped.	Engine below 3400 rpm. Adjust (see "Carburetor out of Adjustment").
<b>Engine Runs but Plate Does Not Vibrate</b>	
Broken belt	Replace.
Broken or worn out clutch.	Replace.
No key on engine shaft.	Assemble key to shaft and clutch hub. See "Maintenance" and "Offset Eccentric Sheave" sections of this manual.
Eccentric seized.	Check to see if it is free turning. If not, disassemble. Wear on shaft and inner race of bearing is normal.
<b>Unit Vibrates When Throttle is in Idle</b>	
Engine idles too fast.	Free up throttle linkage. Adjust idle speed as in "Carburetor improperly adjusted"
Defective clutch.	Check for bad parts and replace if necessary.

<b>Noisy Unit</b>	
Loose or broken part.	Tighten and/or replace
Defective eccentric bearing.	Replace.
Defective clutch.	Replace.
Engine operating below 3400 rpm.	Consult engine manual for correct RPM. (see "Engine is not at 3400 rpm")
<b>No and/or Insufficient Water Flow</b>	
Water tank empty.	Fill tank.
Sprinkler shut off.	Open valve.
Plugged parts.	Remove end fittings and sprinkler tube, if necessary, and clean.

**CALIFORNIA PROPOSITION 65 WARNING:** Operation of this equipment and/or engine exhaust from this product contains chemicals known to the State of California to cause cancer, birth defects, or other reproductive harm.

# NOTES

## NOTES



**MARSHALLTOWN**  
*The Premier Line*

Marshalltown, IA  
Phone 800-888-0127 / 641-753-0127  
Fax 800-477-6341 / 641-753-6341  
[www.MARSHALLTOWN.com](http://www.MARSHALLTOWN.com)